

الجمهورية العربية السورية
وزارة التربية والتعليم

Emar

English Series

Workbook

2

2025 - 2026

حقوق الطباعة والتوزيع محفوظة للمؤسسة العامة للطباعة
حقوق التأليف والنشر محفوظة لوزارة التربية والتعليم
الجمهورية العربية السورية

1

Welcome Back

1

Read and match.

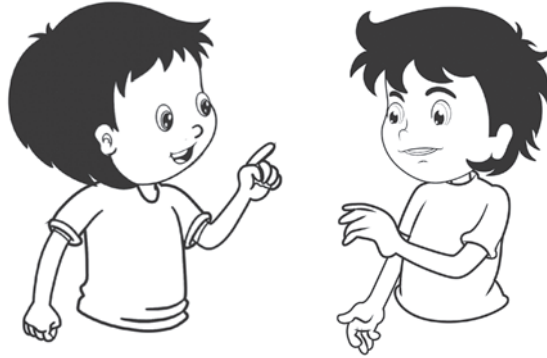

1- Hello!

2- What's your name?

3- How old are you?

4- Where do you live?

- I'm seven.

- I live in London.

- Hi!

- I'm Mark.

2

Write the numbers.

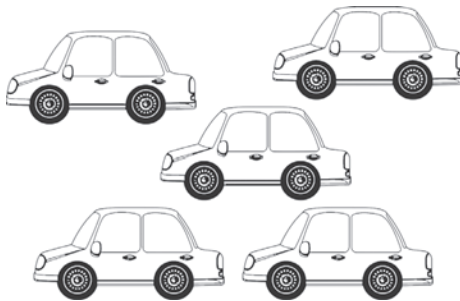

How many cars?

..... cars.

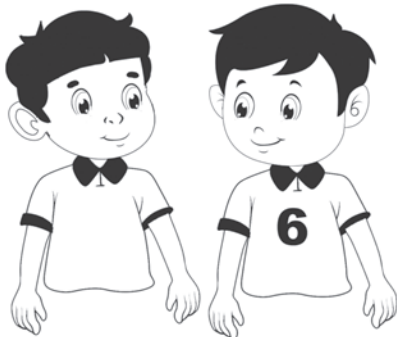

How old are you?

I'm



There are
balls.



Listen and circle.



1- My name's (Julia , Tom).

2- I'm (seven , eight).

3- I live in (London , Damascus).



Write about you.

My name is

I live in

I'm

5 Read, trace and match.

1- apple

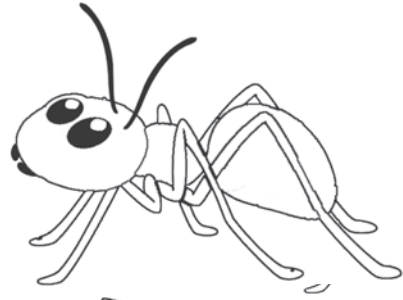

2- ant

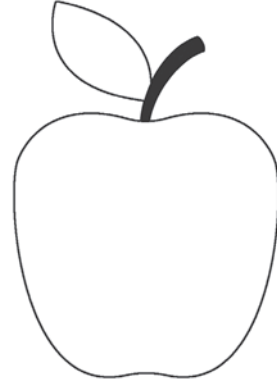

3- mat

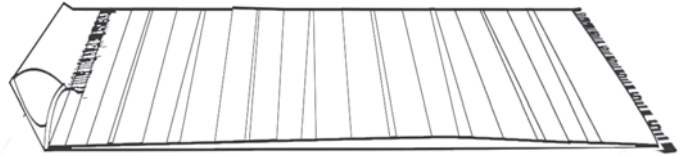

6 Trace then copy.

A

a

mat

cat

2

Our New Classroom

1 Read and circle classroom objects.

1- rubber - dog - cat - sun

2- bike - piano - policeman - notebook

3- elephant - pencil case - train - bird

4- plane - ruler - grandmother - tree

2 Listen and match.

1- They are rulers.

2- They are posters.

3- These are pencil cases.

4- These are notebooks.

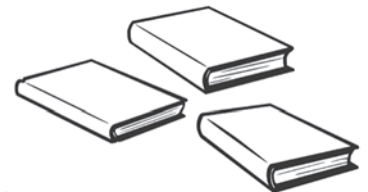
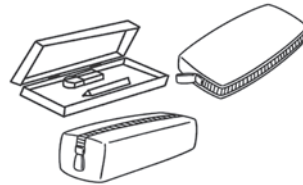

3 Draw two objects you see in the classroom then write their names.

Detailed description: A large, empty rounded rectangle with a blue border, intended for a student to draw an object and write its name.

1-.....

Detailed description: A second large, empty rounded rectangle with a blue border, identical to the first one, for drawing and writing.

2-.....

4 Read and circle.

1- Tom is (next to , behind) the door.

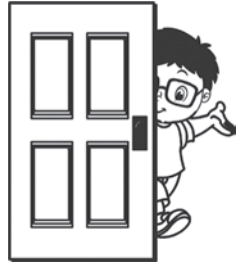

2- The table is (between , on) two chairs.



3- These are (rulers , posters).

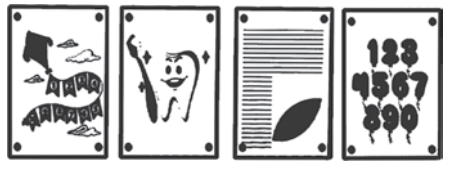



4- They are (pencil cases , notebooks).

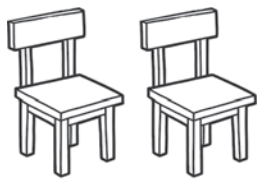

5 Listen and tick (✓).

1-   

2-   

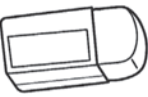
3-   

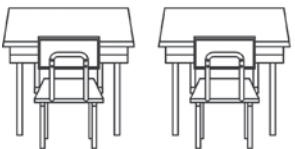
4-   

6 Colour the pictures with (b).

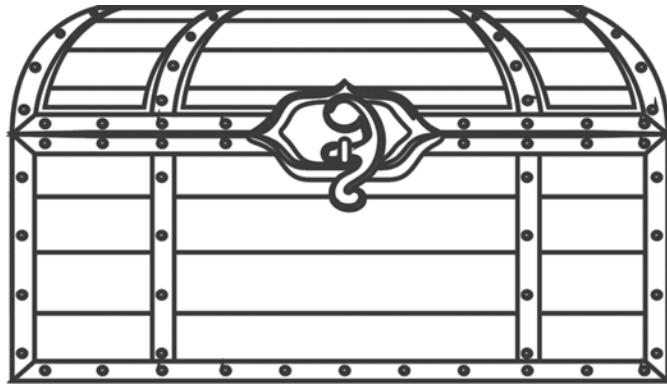
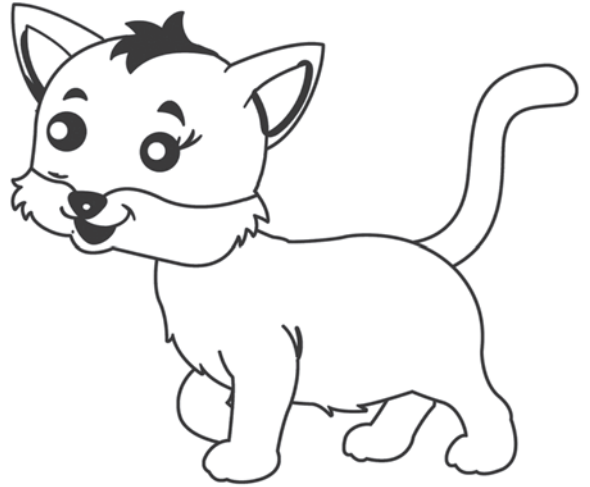

7 Trace then copy.

B

b

rubber

bird

3

New Friends

1 Read and circle.

1-[That , Those] are books.

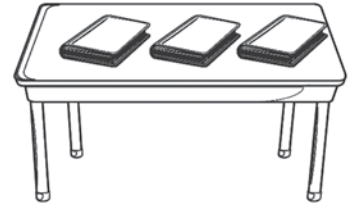

2-[That , Those] is a pencil case.

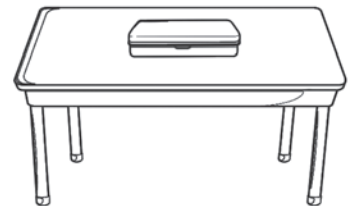

3-[That , Those] are balls.



2 Find and write.

y o c l e v e r y

y a c t i v e y k

z h e l p f u l y

y y c u t e y x

3 Listen and number.

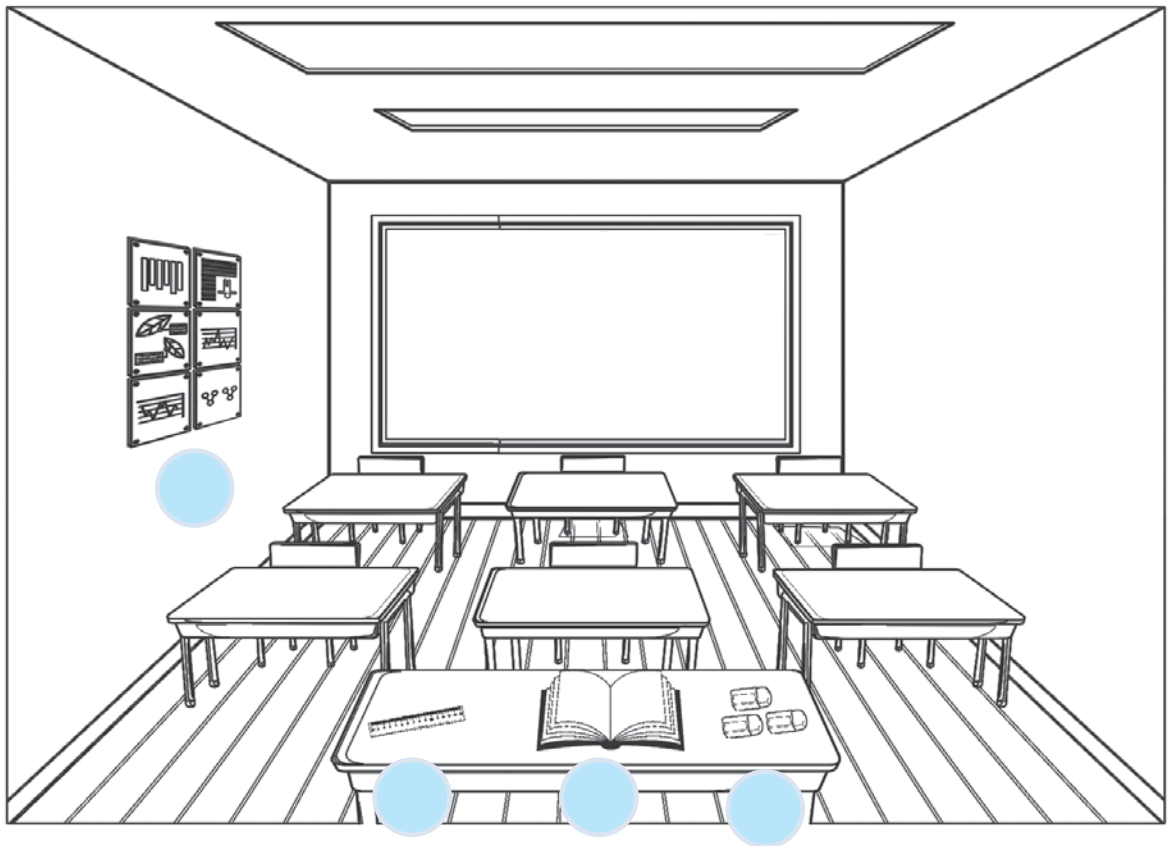

4 Look and draw 😞 😊 .

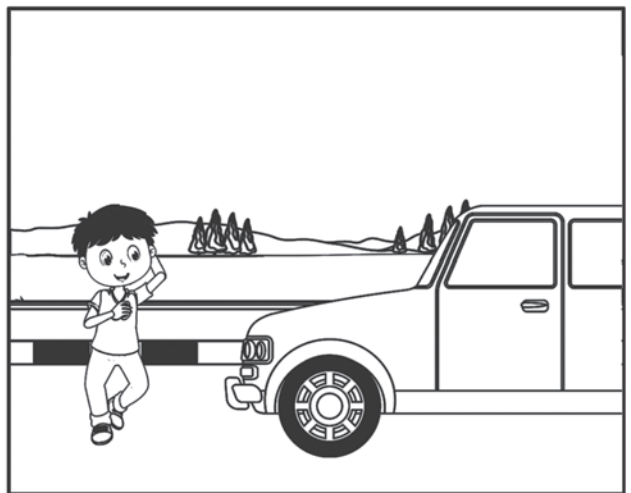
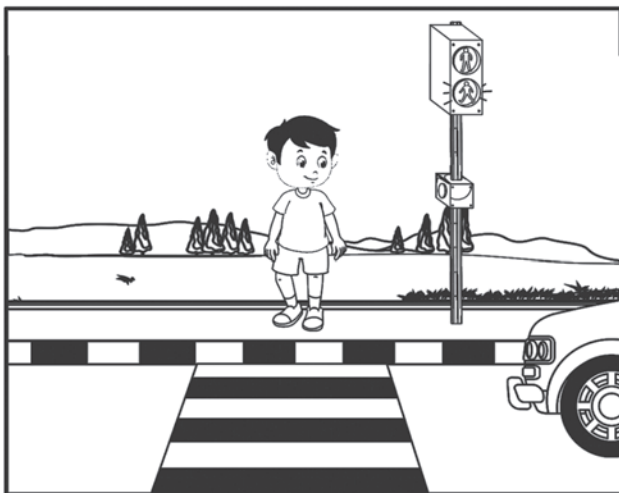

5 Match then trace.

egg

ten

wet

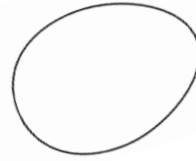

10

6 Trace then copy.

E

e

wet

elephant

4

Follow the Rules

1 Look and match.

1-Don't shout.

2-Don't run in the corridor.

3-Listen to the teacher.

4-Keep your classroom clean.

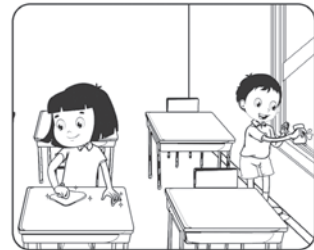

2 Fill in the spaces.

bin , shout , listen

Hello, My name's Sally. I am seven. I like my school. I..... to my teacher. I put the rubbish in the.....I don't in the classroom.





Listen and tick (✓).

1- Run in the corridor.

Don't run in the corridor.

2- Keep your classroom clean.

Don't keep your classroom clean.

3- Listen to the teacher.

Don't listen to the teacher.



Look and circle.

1. Put the rubbish in the bin.



2. Run in the corridor.



3. Shout in the classroom.



4. Listen to the teacher.





Listen and write the missing letter.



b__ack

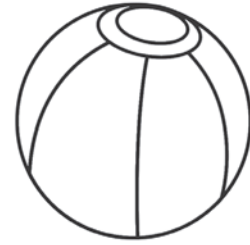

ba__l



__emon

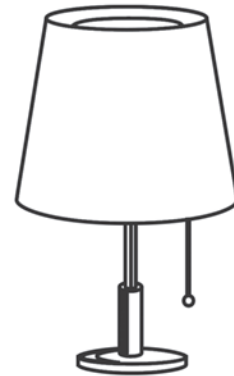

__amp



Trace then copy.

L

l

lamp

ball

5 Revision 1

1 Listen and tick (✓).

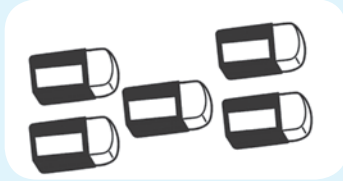
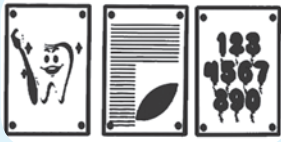

2 Look and write (That , These , This , Those)

1-..... is a car.



2-.....are my pens.



3-.....is my house.

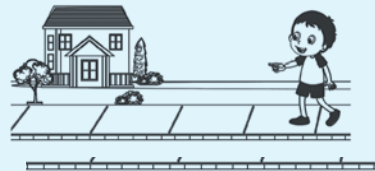

4-..... are flowers.



3 Read and circle.

- 1- There is a ruler (**under** , **behind**) the bag.
- 2- There is a pencil (**on** , **between**) the bag and the pencil case.
- 3- The pencil case is (**under** , **on**) the table.
- 4- There is a rubber (**behind** , **under**) the table.

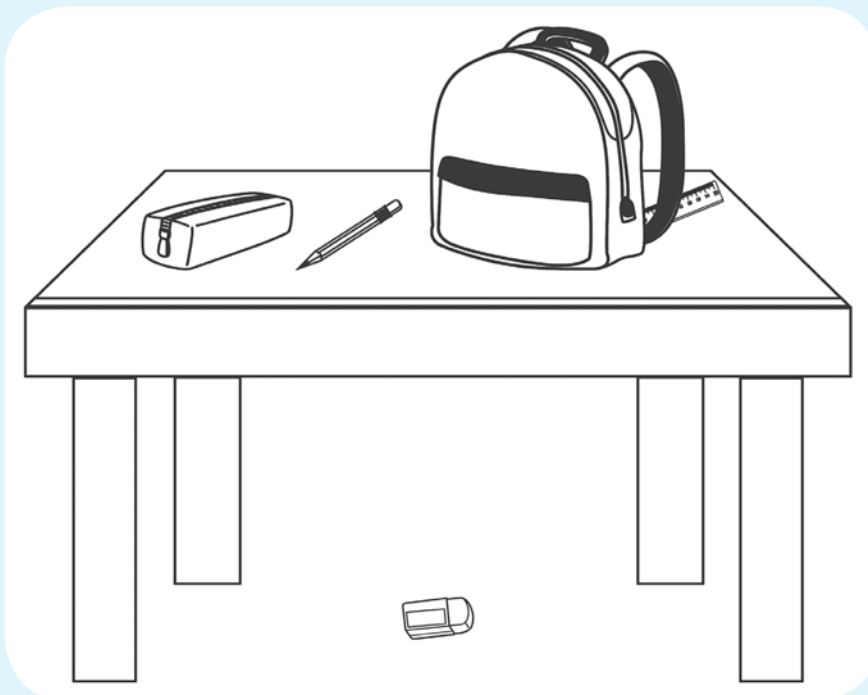

4 Match.

A

E

B

L

I

e

a

b

5 Read, circle then write.



b p d

__utterfly

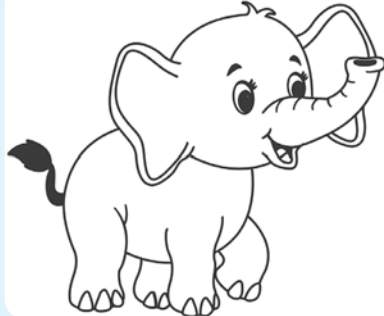

k e m

__lephant

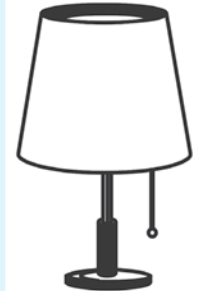

o l n

__amp

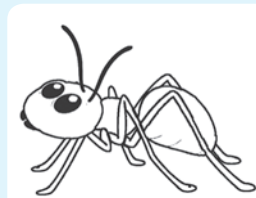

a l b

__nt

6 Unscramble.

d r b i

.....



r a c

.....

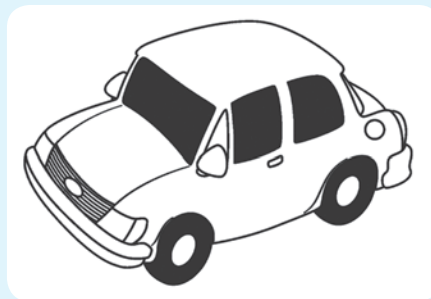

g e g

.....

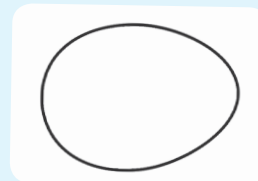

6

In the Park

1 Read and tick (✓).

1- I can see a girl on the swing.
I can see a duck in the river.



2- Mark is up the climbing frame.
Sally is down the slide.



2 Look and complete.

on , up , behind , under



- 1- The bike is the bus.
- 2- I can see a girlthe slide.
- 3- There is a boy the climbing frame.
- 4- I can see a dog the tree.





Listen and draw.

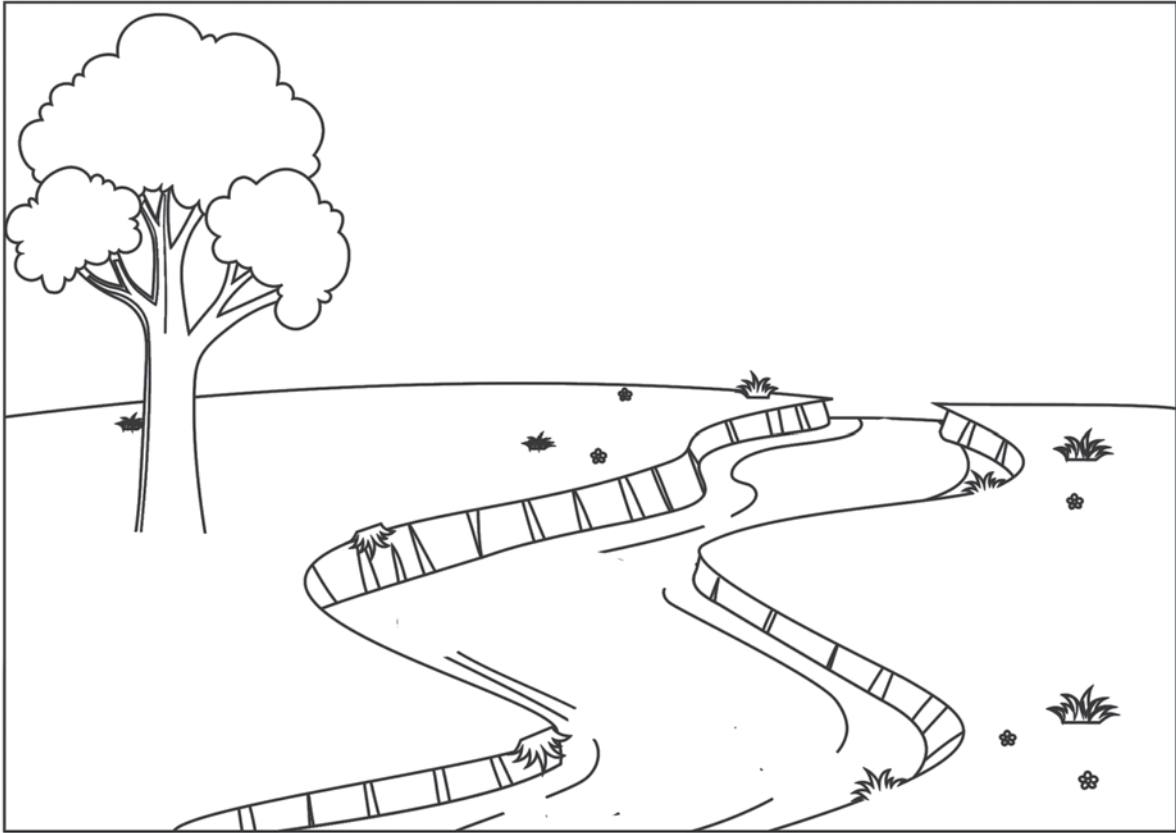

Look, circle and write.



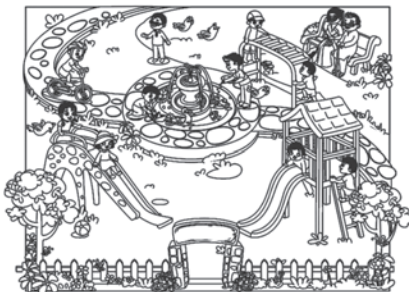

				p	
S	e	e	s	a	w
w			l	r	
i			i	k	
n			d		
g			e		





5 Write the missing letter then match.

b__x



f__x



m__nkey

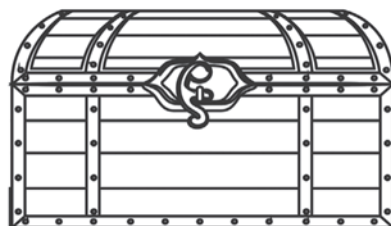

6 Trace then copy.

O

o

okra

octopus

7

At the Toy Shop

1 Look, count and write.

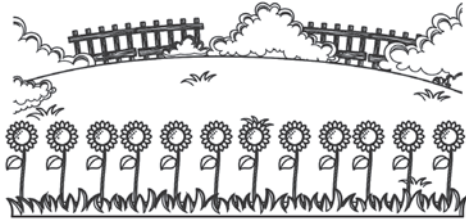

1- There are **12** flowers in the garden.

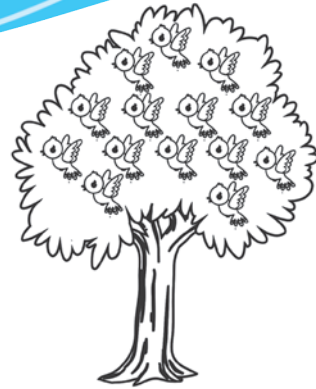

2- There are birds on the tree.

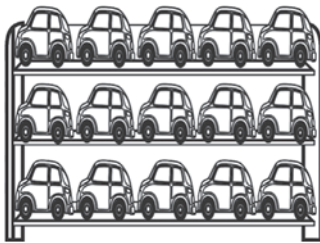

3- There are cars in the toy shop.

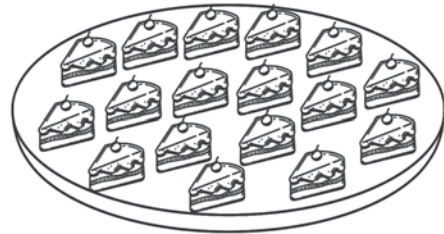

4- There are cakes on the table.

2 Look, count and circle.

1- There are (**thirteen** , **fifteen**) spinners.

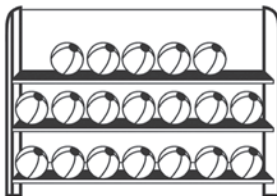
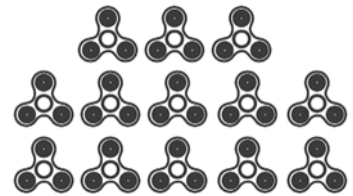

2- There are (**fourteen** , **nineteen**) balls.

3- There are (**twelve** , **sixteen**) robots.

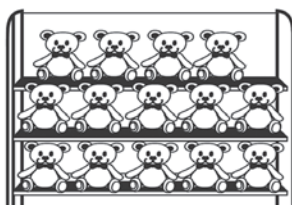
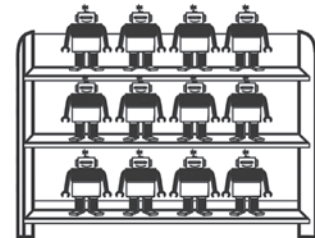

4- There are (**fourteen** , **eleven**) bears.

3 Trace, draw and say.

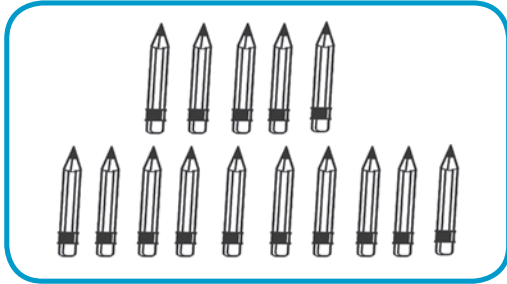

fifteen



eighteen

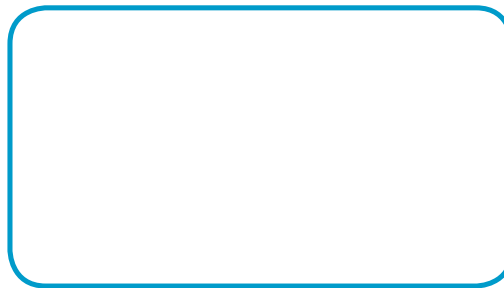

twelve

4 Listen and tick (✓) or cross (x).

1- There are thirteen balls.

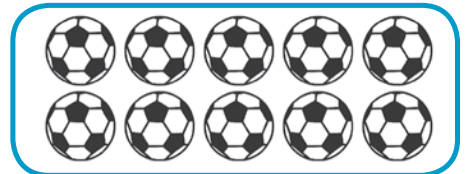

2- There are twenty cups.



3- There are eleven pencils.

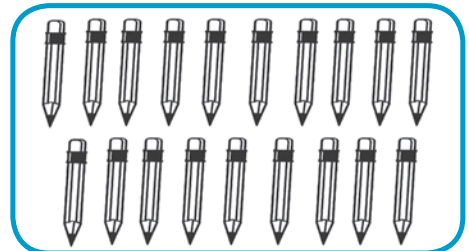

4- There are eighteen rubbers.

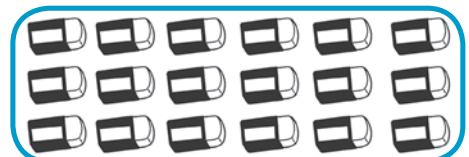

5 Read and circle the letter (c).

A cat can't eat cakes.

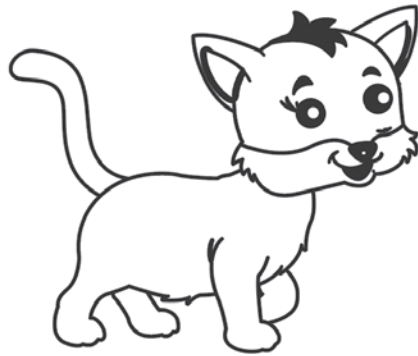

6 Trace then copy.

C

c

cup

car

8

I Like Food



Listen and tick (✓).

1- It's a knife.

It's a fork.



2- It's a pear.

It's an apple.



3- It's a spoon.

It's a plate.



Read and match.

1- Can we have
some fish, please?

2- What would you
like to drink?

3- Where is the fork?

- Some orange
juice, please.

- It's on the table.

- Yes, of course.

3 Unscramble.



a p e t l

.....



n o p o s

.....



k o f r

.....

4 Look and write.

on- under – in – next to

- 1- The doll is the table.
- 2- The hat is the chair.
- 3- The bed is the door.
- 4- The toys are the box.

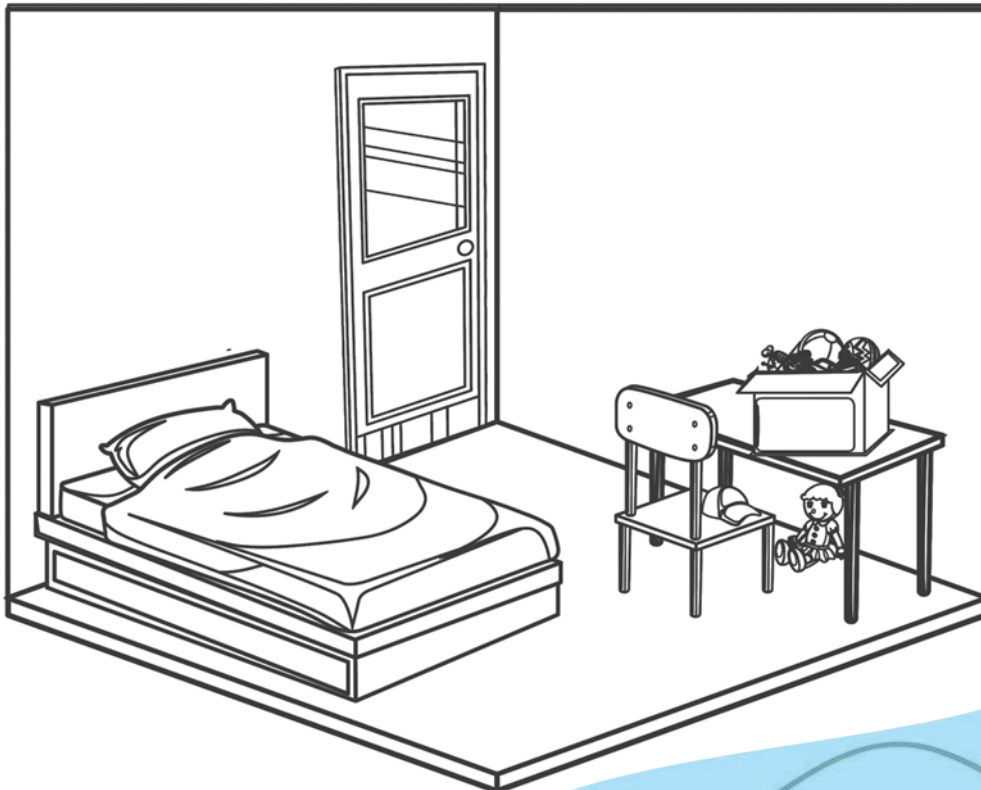



Listen and circle the words that have the (u) sound.



Trace then copy.

U

u

umbrella

fun

9

Computer Games

1 Read then write.

Mary's , Whose, It's

1- **Whose** computer is it?

2- Tom's computer.

3- tablet is it?

4- It's tablet.



2 Listen and tick (✓).

1-

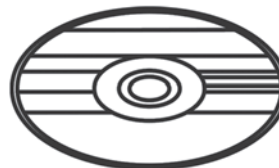
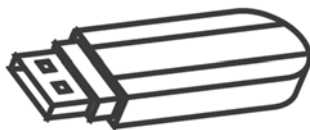

2-



3-



3 Write (his - her).

- 1- It's **her** flash memory.
- 2- It's football.
- 3- It's doll.
- 4- It's tablet.

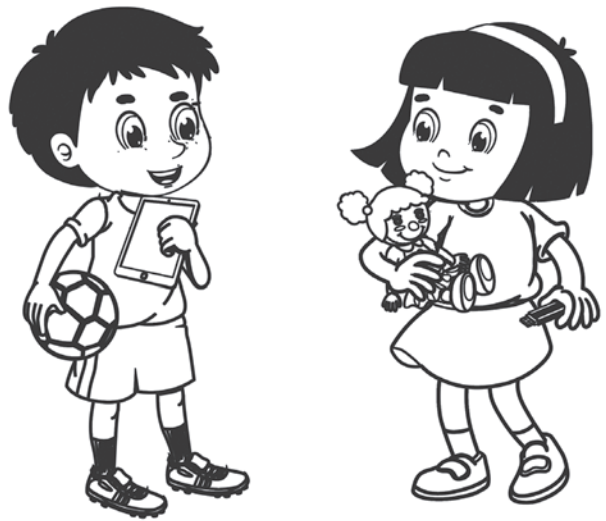

4 Read and colour.

Mary's tablet is red, and her flash memory is green.
Dan's CD is blue, and his playstation is black.



5 Write the missing letter.

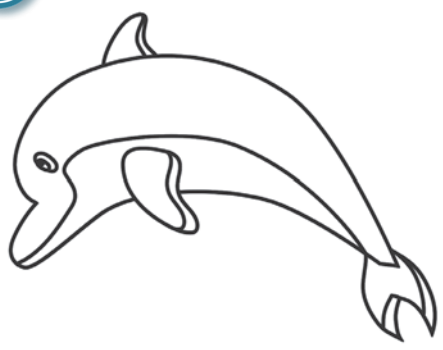

___olphin

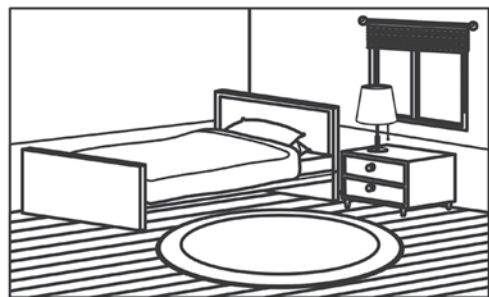

be___room



___og

6 Trace then copy.

D

d

doll

bed

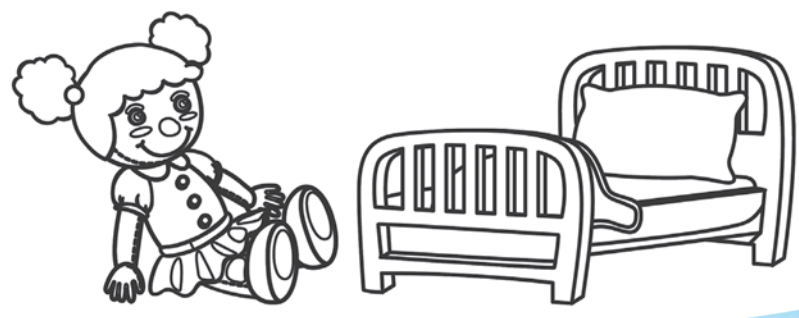

10 Revision 2

1 Read and circle.



1- I'm Tala. I go to the (park , kitchen) with my brother.



2- I go up and down the (swing , slide).



3- I have a (doll , robot). (tablet , play station).

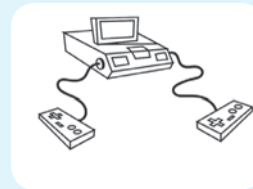

4- My brother has a

2 Trace then write his or her.

1- It's cup.

2- It's playstation.

3- It's skateboard. 4- It's umbrella.



3 Look, circle and write.

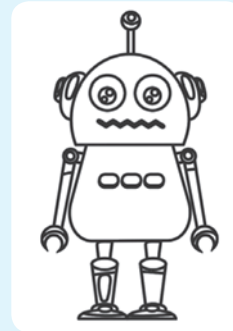
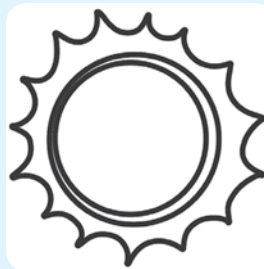

.....

	k	n	i	f	e
s	w	i	n	g	
r	o	b	o	t	
	s	u	n		

4 Join the numbers from 1 to 20, then write.

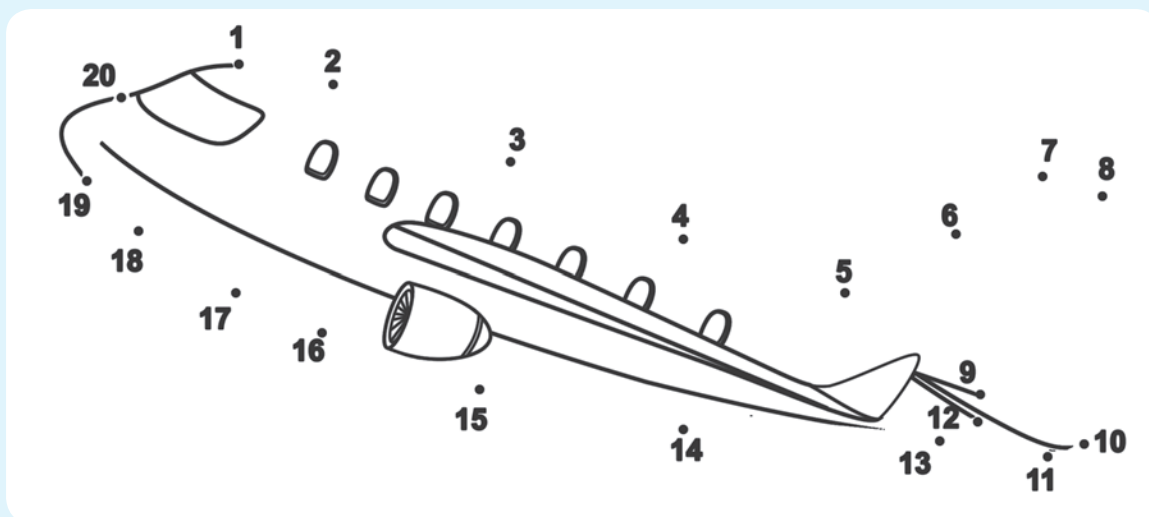

It's a

5 Write the first letter of each picture then write the new word.

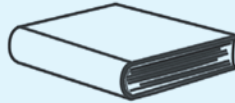

10

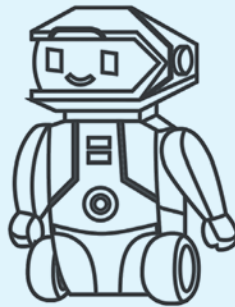

6 Write the missing letter then match.



s__n

d__lphin

f__rk

c__p

__kra

1 Match and say.



2 Look and write.

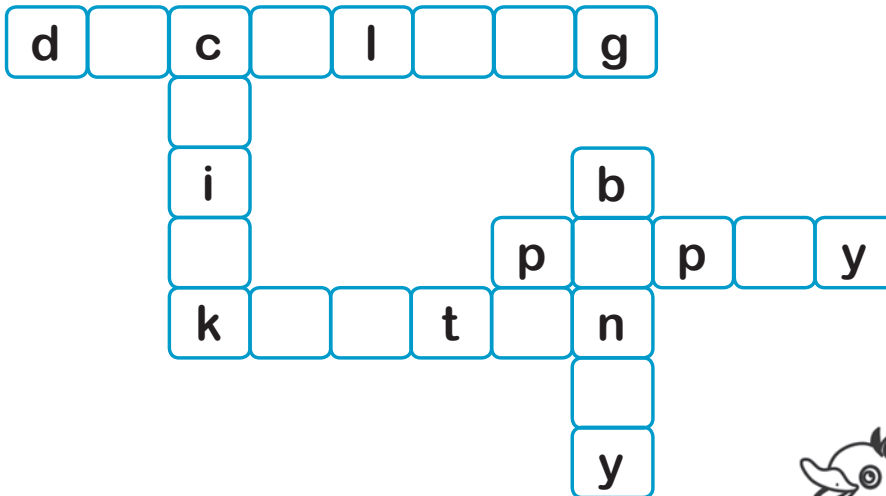

3 Listen and write.

can , can't

1- A puppy fly.



2- A duckling swim.



3- A kitten run.



4 Trace, say and write the word.

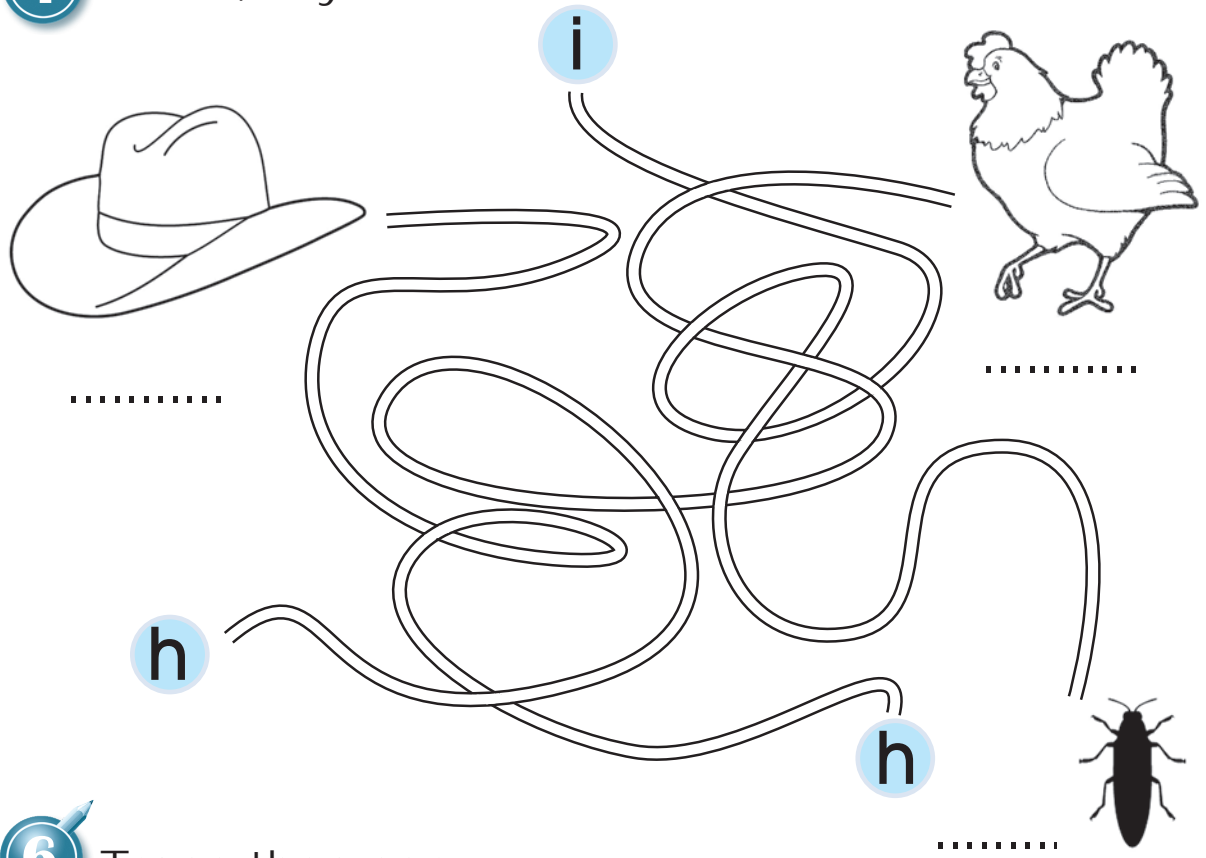

6 Trace then copy.

H
h
I
i
head
fridge

12

Helping at Home



Listen and tick (✓) or cross (x).

1- She's cleaning the kitchen.



2- He's washing the car.



3- They're setting the table.



4- She's playing tennis.



Read and match.

1. Colin is watering the flowers.



2. Jack is listening to music.



3. Tala is setting the table.



3 Read and write.

They're - He's - She's

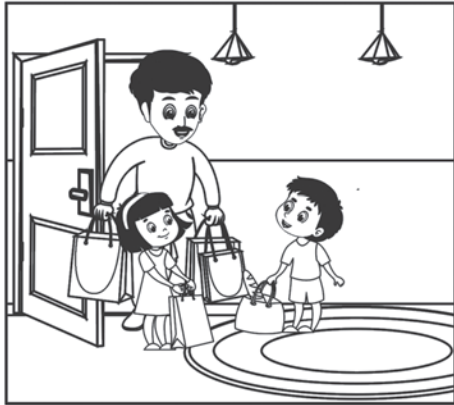

1-..... helping Dad.



2-..... cleaning the garden.

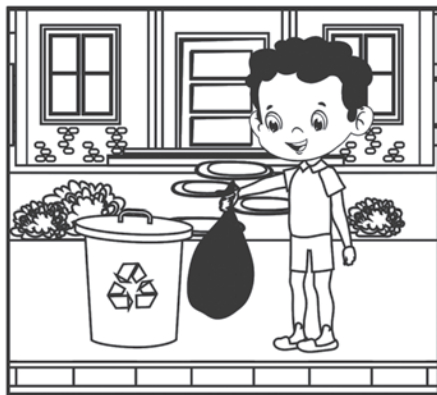

3- putting rubbish in the bin.

4 Unscramble the words.

1- umjp

2- inrg

3- arj

4- aogt



5 Trace then copy.

G

g

J

j

swing

juice

13

On Holiday

1 Listen and circle.

1- She is (fishing , swimming).



2- He is playing (volleyball , football).

3- They are (swimming , drinking).



2 Put the words in the correct basket.

desk- bed – sand castle-
board- book- kitchen-
beach ball- fish - fridge.

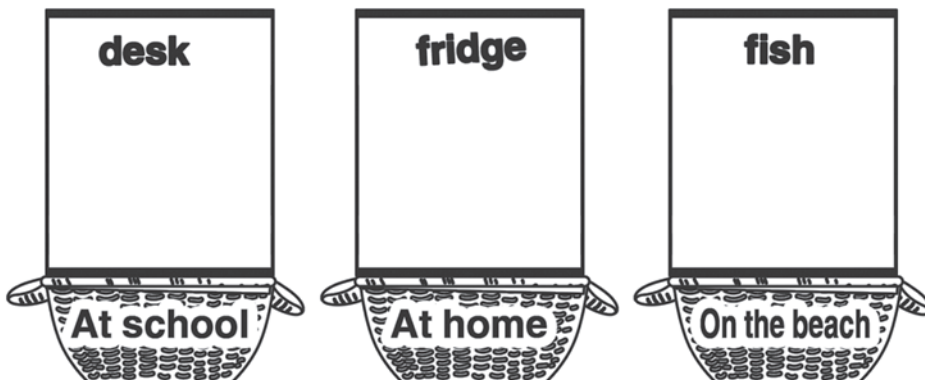

3 Tick (✓) or cross (x).

1- He is swimming.



2- They are playing volleyball.



3- We are fishing.



4 Complete then write.

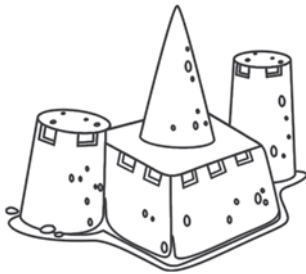

s d c s t

.....

 e h



.....



 u c

.....

 s



.....

5 Write the missing letter.



9



__onkey

ni__e

__ud

__ose

6 Trace then copy.

M

m

mud

N

n

nut

14

Happy New Year



Listen and tick (✓).

1-Where are the red balloons?

They're in the bedroom.

They're in the living room.

2-Where's the mango juice?

It's in the kitchen.

It's on the table.

3-Where are the candies ?

They're under the box.

They're behind the box.



Read and write the things you need for a party.



juice

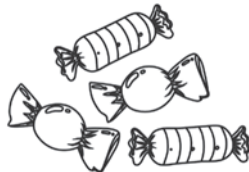

candies



cakes

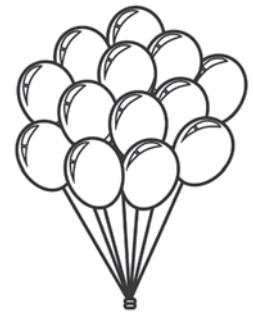

balloons



rubbers

A large rounded rectangular box with four horizontal dotted lines for writing.

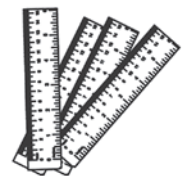

rulers

3 Let's play.

Guess then draw what's missing.

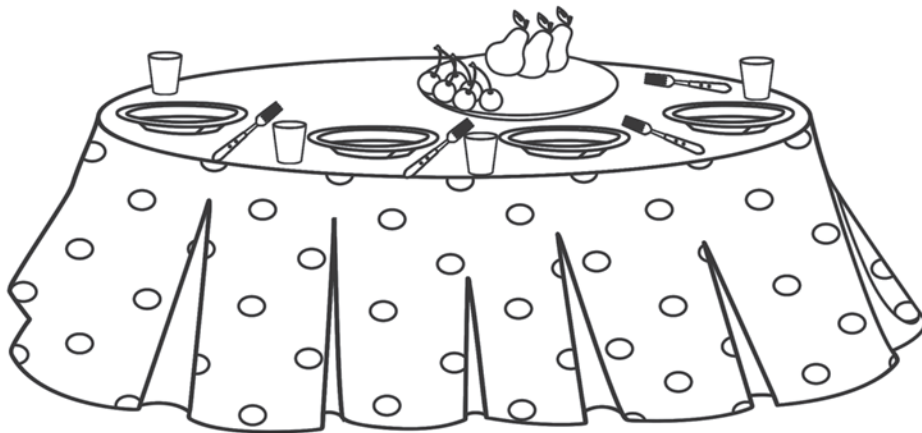
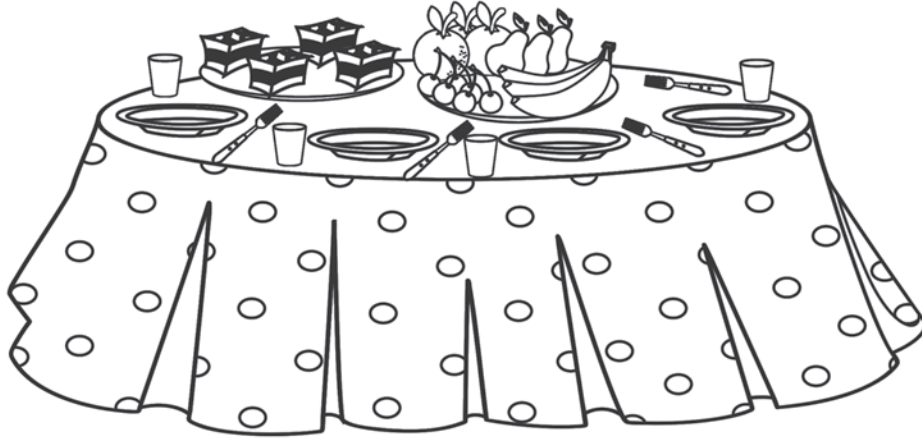

4 Look, write and say.

1- There are some  in the kitchen.

2- The  are on the table.

3- The balloons are under the .

4- The book is next to the .

5 Look and match.

S

P

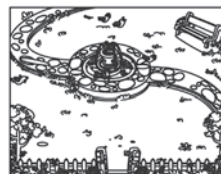

6 Trace then copy.

S

s

star

P

p

pear

15 Revision 3

1

Read and write.

swimming , cherries , pears , fishing ,
building , pineapples

Food

.....
.....
.....

Activities

.....
.....
.....

2

Read then tick (✓) or cross (x).

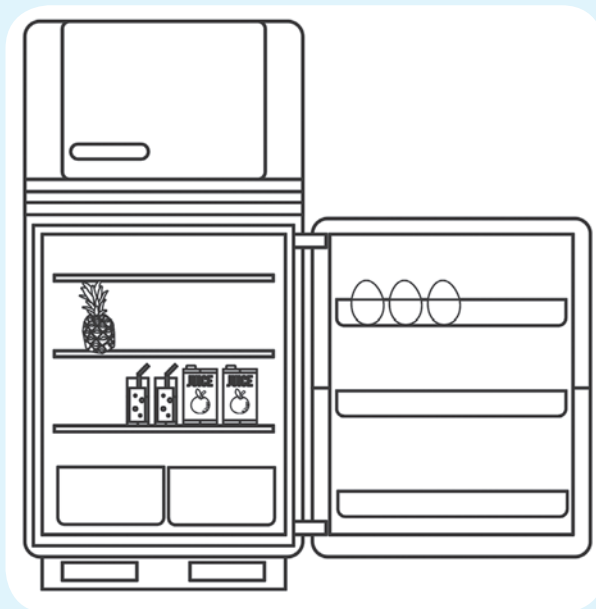

What's in the fridge?

1- There is some juice.

2- There are some cherries.

3- I can see one pineapple.

4- I can see some eggs.



Listen and match.

1- They're drawing pictures.

2- We're running in the garden.

3- He's playing on the computer.

4- She's eating a sandwich.



Read and write.

He's , They're , She's



..... watching TV.



.....building a castle.



..... flying in the sky.

5 Read, circle and write.



- 1- My mother is..... the table. (listening , cleaning)
- 2- My father is a book . (reading , setting)
- 3- I am the flowers. (watering , making)
- 4- My grandma is water. (washing , drinking)

6 Write then match.

.....ead

fr.....dge

.....uts

.....alad

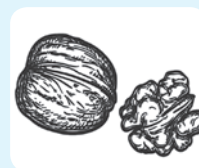

16

Daily Routine

1 Write the days of the week in the correct order.

Wednesday , Saturday , Tuesday ,
Monday , Friday , Thursday

Sunday
.....
.....
.....
.....
.....
.....

My favourite day is

2 Read and tick (✓).



I watch TV.

I go shopping.

I drink milk.

I ride a bike.

I go swimming.

I read a story.



Listen and number.

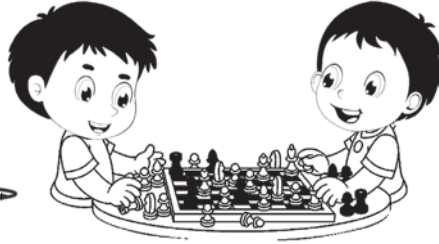

Read and complete.

read - ride - play



I stories on Monday.



I computer games on Wednesday.

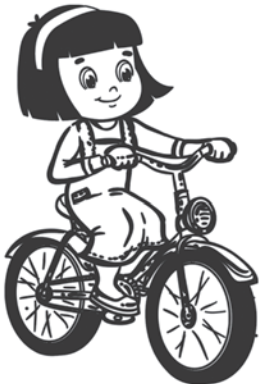

I my bike on Tuesday.

5 Look, circle and say.

k



q

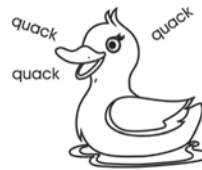

6 Trace then copy.

K

k

key

Q

q

quack

17

Telling the Time

1 Read and tick (✓).

1- I have dinner at three o'clock.



2- I do my homework at four o'clock.



3- I help my mother at five o'clock.

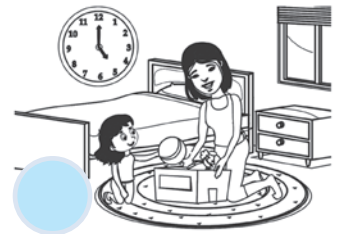

2 Listen then order.

- I have dinner at four o'clock.
- I go to bed at nine o'clock.
- I get up at six o'clock.
- I go to school at seven o'clock.



Read and match.

1- It's seven o'clock.

2- It's four o'clock.

3- It's one o'clock.

4- It's ten o'clock.



Read and draw the time.

1- I get up at six.

2- I go to school at eight.

3- I go to bed at nine.

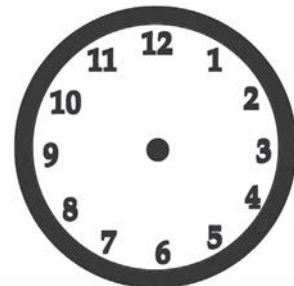

5 Circle the beginning letter.

b - f - r



r - a - f



c - r - f



f - r - k



6 Trace then copy.

F

f

face

R

r

rain

18

Meet My Family



Listen, read and match.

1- A doctor works in

- a police station.



2- A policeman works in

- a school



3- A cook works in

- a hospital



4- A teacher works in

- a restaurant



Read and write.

cook - pupil - bank - aunt

1- My is nice.



2- My father goes to the at 10 o'clock.



3- My cousin is a



4- My uncle is a



3 Read then tick (✓) or cross (x).

1- A cook works in a restaurant.



2- A doctor works in a hospital.



3- A teacher works in a bank.



4- A policeman works in a school.



4 Sort the words.

~~doctor~~ - ~~uncle~~ - ~~police station~~ - ~~aunt~~
- cook - hospital - cousin - banker -
school

Family

uncle

.....

.....

Place

police station

.....

.....

Job

doctor

.....

.....

5 Write **y** or **x** then match.

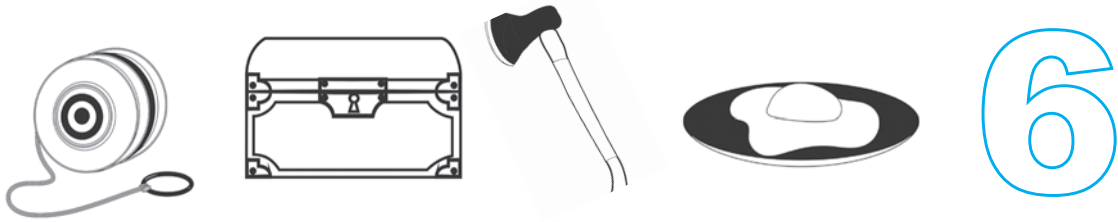

si _

_ o _ o

_ olk

a _ e

bo _

6 Trace then copy.

X

x

axe

Y

y

yolk

19

At the Weekend

1 Read and match.

1- She listens to music.



2- He visits his grandmother.



3- My mother goes to the gym.



4- My father goes shopping.





5- They play football.





Listen and tick (✓).

			
Lara	✓		
Frank			
Mike			



Look and circle.

1- Sally TV.



2- He a book.



3- I have breakfast in the .



4- He rides his



4 Write the missing letter then match.



..... able

.....oo

.....ebra

.....wo

.....ent

5 Trace then copy.

Z

z

zero

T

t

tooth

20 Revision 4

1 Read and colour.

Sunday = red

Monday = yellow

Tuesday = green

Wednesday = blue

Thursday = orange

Friday = pink

Saturday = purple

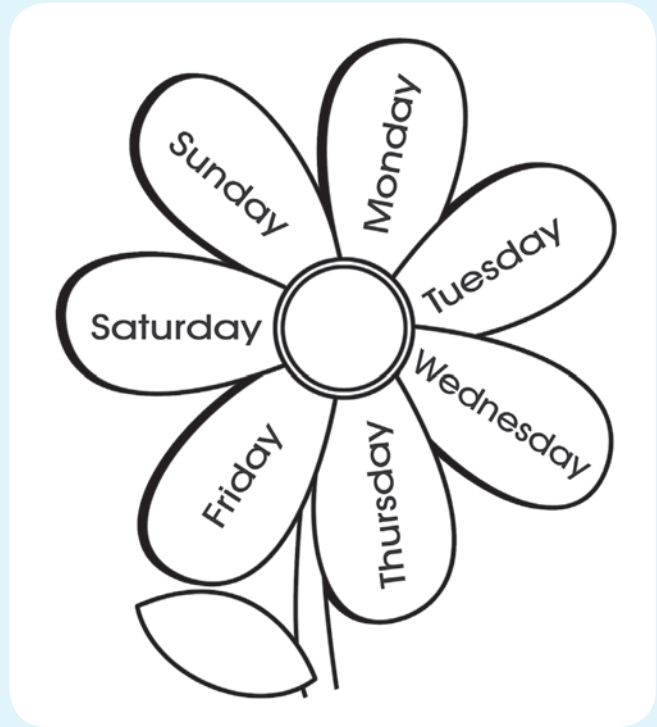

2 Look then tick (✓) or cross (x).

1- My uncle is a teacher.



2- My Mum is a doctor.



3- My father is a policeman.

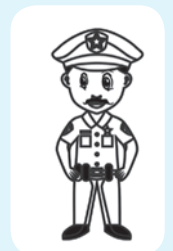

4- My aunt Maria is a cook.





Listen, read and match.

What do they do at the weekend?

1- Sally reads a story.

2- Sofia and her mother go shopping.

3- Mike plays on the swing.

4- Maya listens to music.

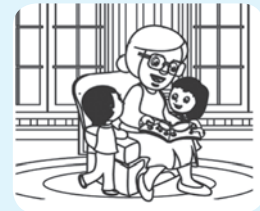

Read and write the correct words.

goes , play , visit , works

1- We our grandmother on Sunday.

2- I computer games with my brother.

3- A cook in a restaurant.

4- My sister to the gym at the weekend.

5 Write the missing letter then match.



__ain

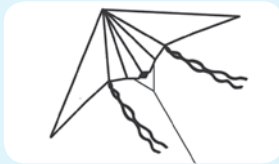

__lower



__ite



yo__o

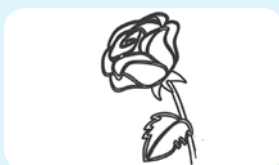

__ueen



__omato

6 Write in the alphabetical order.

zoo , restaurant , kite , aunt , cake

1- aunt

2-

3-

4-

5-



1 Listen and tick (✓).

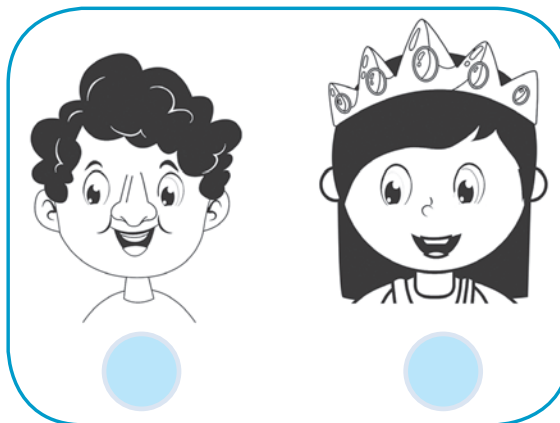
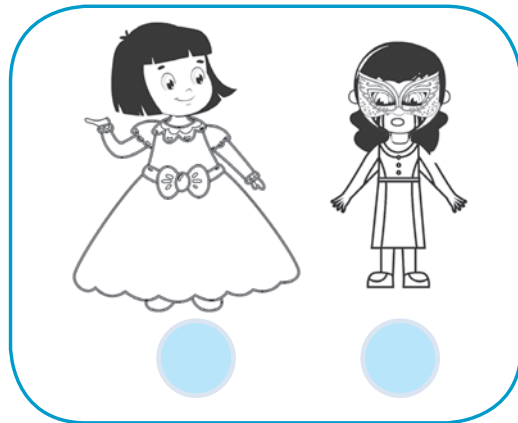
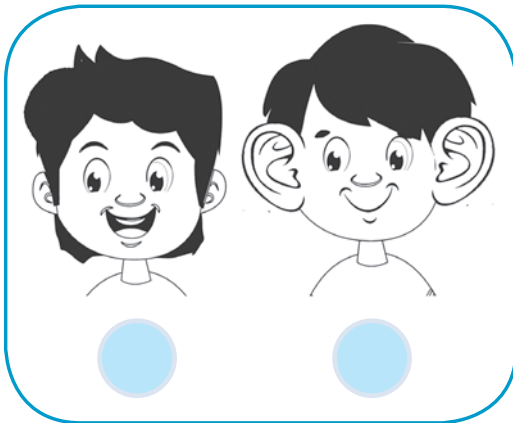

2 Circle the correct answer.

1- He's got a (mask , hat).

2- She's got (short , long) hair.

3- She's got a (crown , dress).

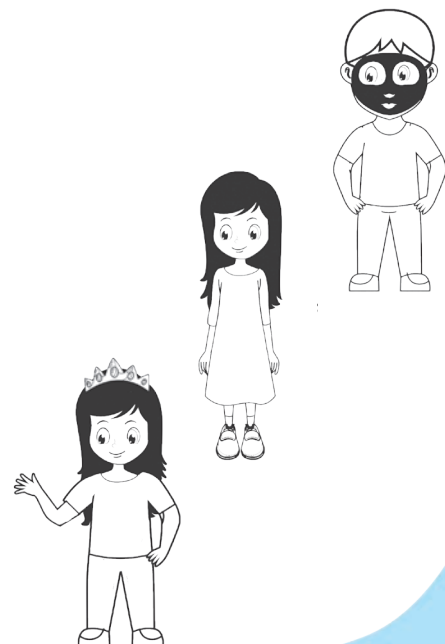

3 Find letters to complete the words.



__r__wn



__a__k

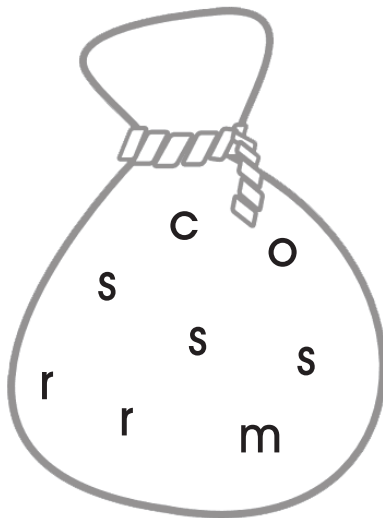

t__ou__ers



d__es__

4 Colour.

- He's got a red nose.
- He's got pink hair.
- He's got black trousers.
- He's got blue shoes.



5 Write the words under (w- v).

watch , van , window , snow , vase , Steve

w

.....

.....

.....

v

.....

.....

.....

6 Trace then copy.

W

w

watch

V

v

vase



Listen, read and match.



1- Sally has got a cough.

2- I've got a headache.

3- I've got a sore throat.

4- She's got a toothache.

5- He's got an earache.



2 Look, read and tick (✓).

1- Has Joe got a toothache?

Yes, he has.

No, he hasn't.



2- Has Smith got a fever?

Yes, he has.

No, he hasn't.



3 Look and complete.

1- She's got a



2- He's



3- I



4 Find and write.



sore throat doctor cough earache



5 Write the words under (d, t).

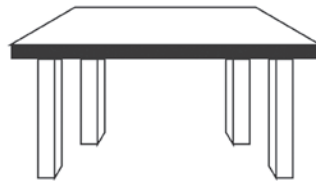

d

.....

.....

.....

t

.....

.....

.....



What's the Weather Like?



Listen and number.

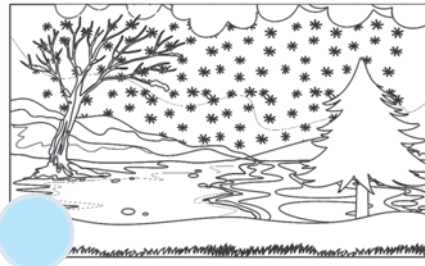
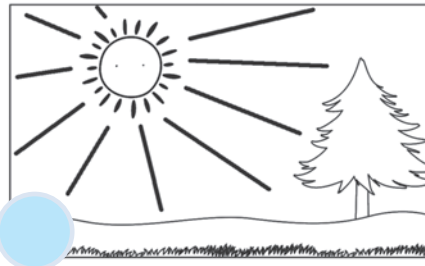

Read and draw.

1- It's rainy in winter.

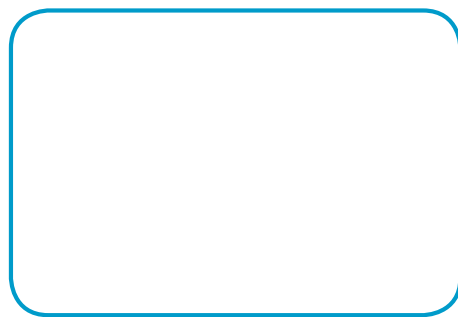

2- It's sunny in summer.

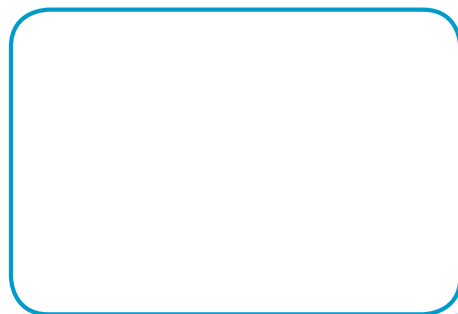



Listen and match.

1- It's windy.

2- It's snowy.

3- It's rainy.

4- It's sunny.

- Let's make a snowman.

- Let's play in the garden.

- Let's fly a kite.

- Let's take the umbrella.



Unscramble the words.



1- i w n d y

.....



2- n s o w y

.....



3- a i r n y

.....



4- n s u n y

.....

5 Look and trace the correct word.

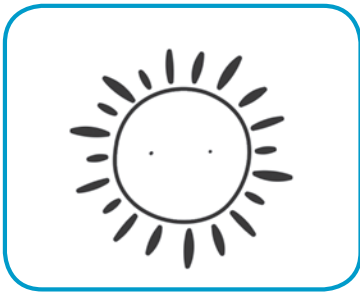

cloudy sunny



snowy windy



rainy windy



rainy cloudy

6 Write the missing letter then match.

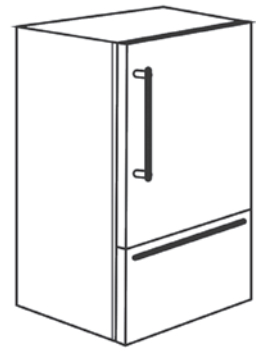

__xe

nu__s

fri__ge

o__ra

lollipo__

1 Listen and tick (✓).

1-

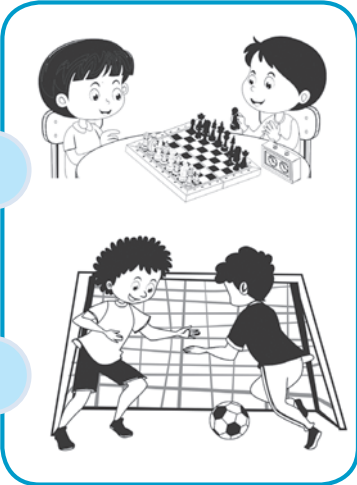

2-



3-



2 Read and circle.

1- I like (chess , swimming).



2- We (like , don't like) drawing.



3- I like (playing , collecting) shells.



3 Complete.



like



don't like

- 1- I tennis.
- 2- I chess.
- 3- I computer games.
- 4- I stories.

4 Listen and tick (✓).

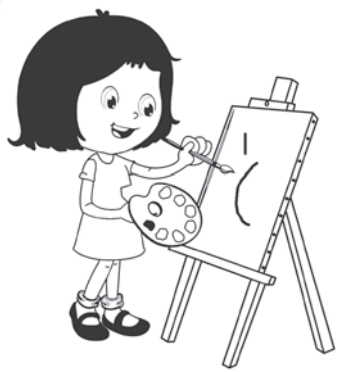

Sally likes reading stories.



He likes football.



She likes swimming.

5 Find and write.

car

1-

2-

3-

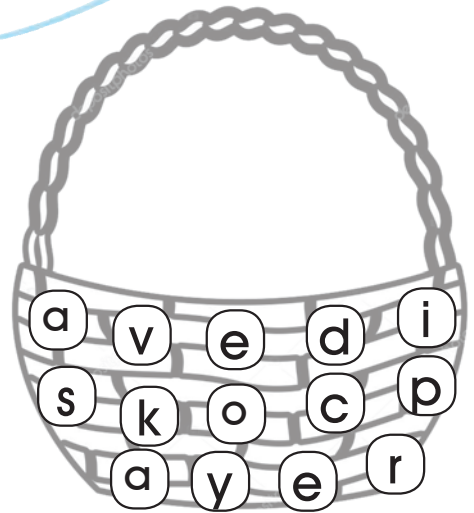

6 Draw your hobby and say.

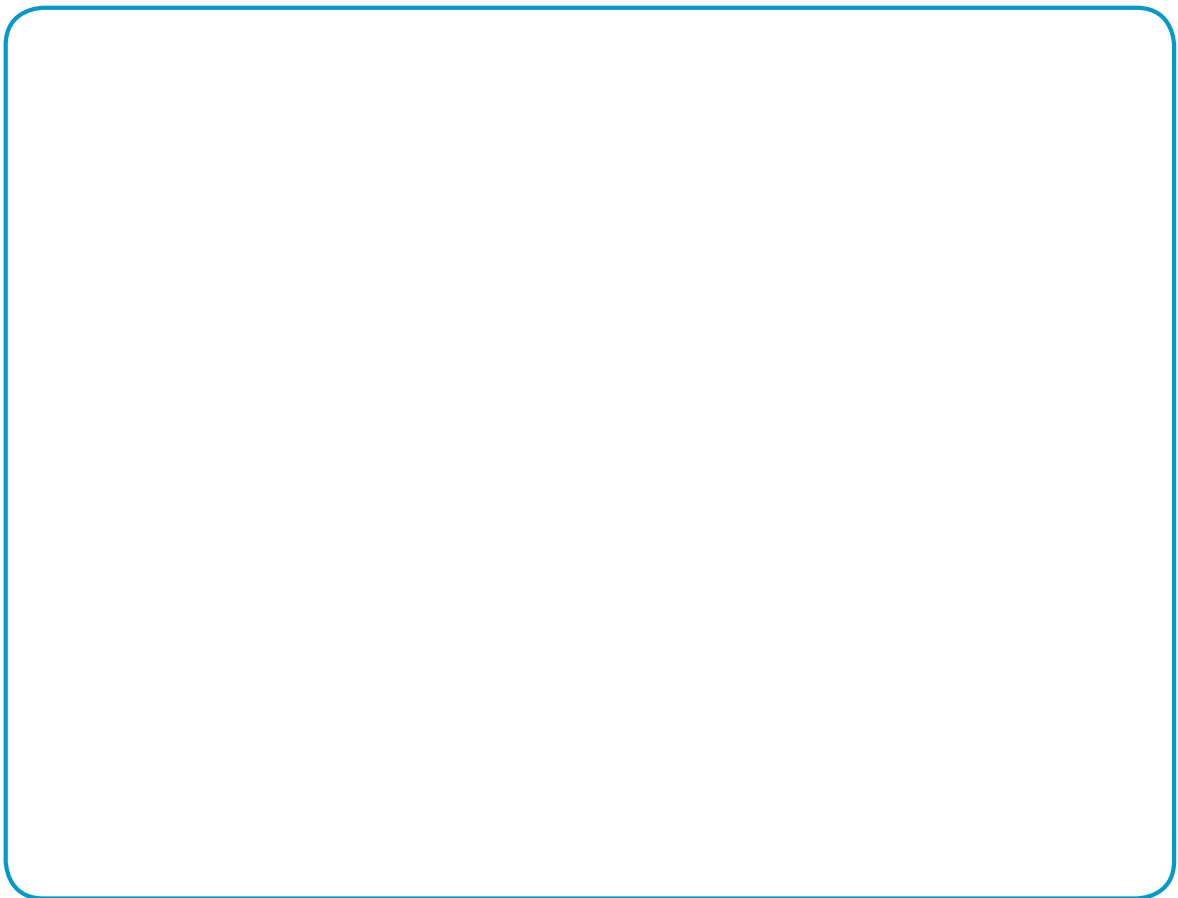

I like

25 Revision 5

1 Listen and circle.

1- Alex likes (playing chess , drawing).



2- Tom likes (swimming , collecting shells).



3- We like (playing football , reading books).



2 Read and write.

rainy – sunny- cloudy – windy

1- The weather is



2- It's

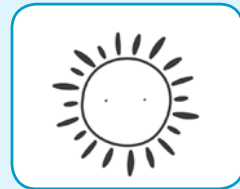

3- The weather is



4- It's



3 Read and match.

1- Emma has got a fever.



2- Max has got a toothache.



3- Dan has got an earache.



4- Juli has got a cold.



4 Sort and write.

dress , swimming , cloudy , drawing ,
trousers , snowy

hobbies

.....
.....

weather

.....
.....

clothes

.....
.....

5 Write in the alphabetical order.



ant, , , , , zoo

6 Write about yourself.

- 1- My name's
- 2- I'm years old.
- 3- I live in
- 4- I like
- 5- I don't like.....

1-My name's Mark.
2-I'm seven years old.
3-I live in London.
4-I like painting.
5-I don't like swimming.

Handwriting Practice



Trace then copy.

A

a

mat

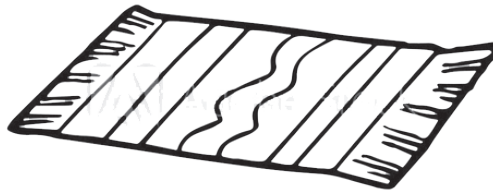

B

b

rubber

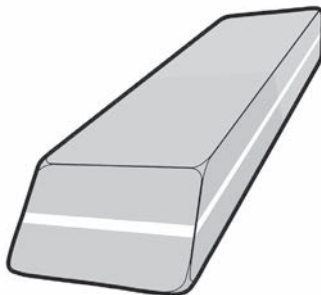

E

e

wet



L

l

lamp



O

o

doll



C

c

cup



S

s

sun



D

d

bedroom



H

h

head

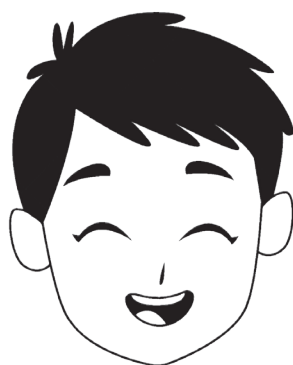

I

i

six



G

g

swing

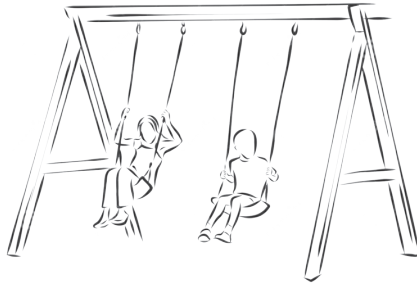

J

j

jacket



N

n

nuts



M

m

moon

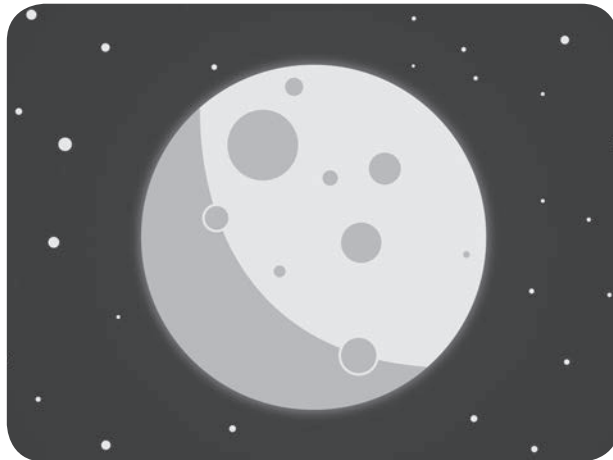

P

p

pineapple



K

k

Key



Q

q

queen



R

r

ruler

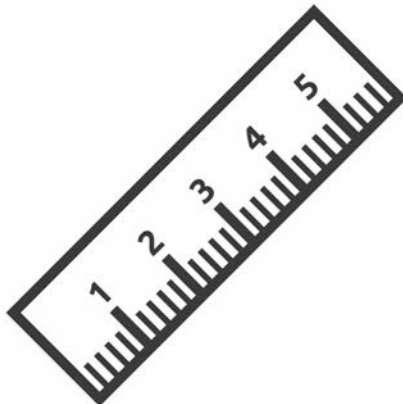

F

f

face



X

x

axe

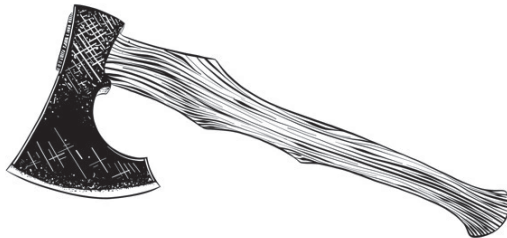

Y

y

yoyo



T

t

table



Z

z

ZOO

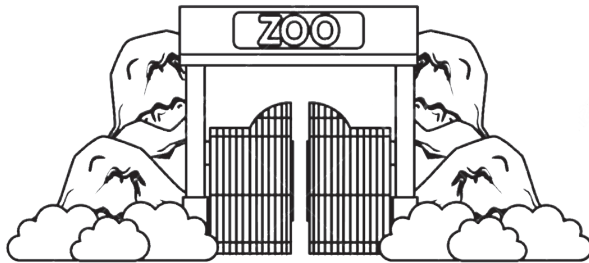

V

v

vase



U

u

umbrella



W

w

watch



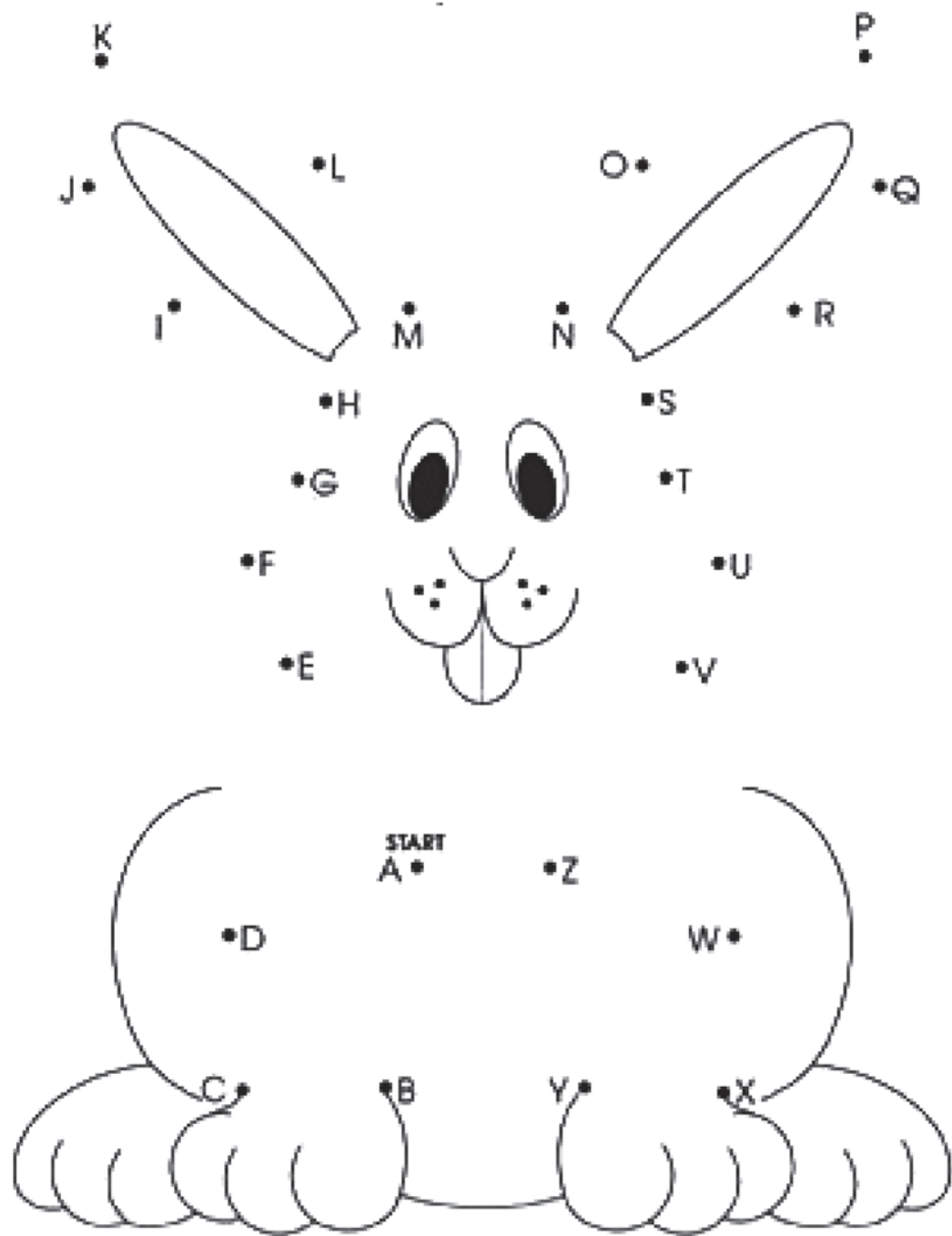



Trace then copy.

11

eleven

12

twelve

13

thirteen

14

fourteen

15

fifteen

16

sixteen

17

seventeen

18

eighteen

19

nineteen

20

twenty

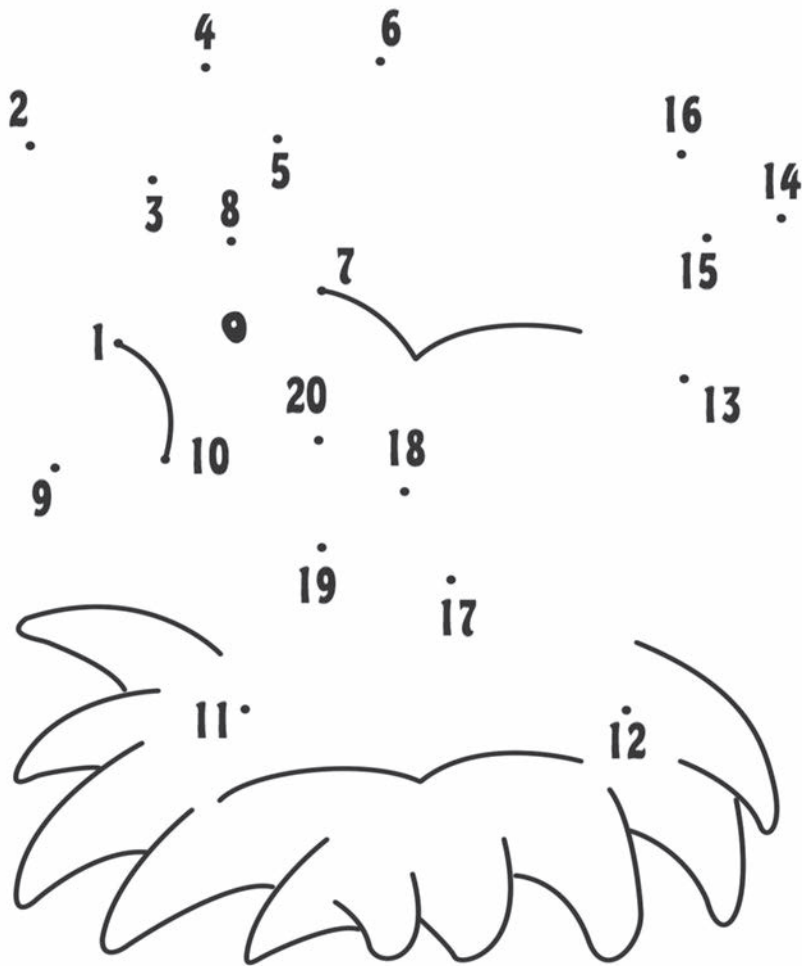

I live in Syria.

I like my school.

My friend is very kind.

Put the rubbish in the bin.

There are eleven robots.

This is her tablet.



A duckling can swim.

I visit my grandparents on Friday.

A doctor works in hospital.

Rama has got a green dress.

I've got a toothache.

It's rainy today.